

ET 210 *Inert* eluent tray

User manual

192.0010, Edition 5, 2024



Copyright ©2024, Antec, The Netherlands. Contents of this publication may not be reproduced in any form or by any means (including electronic storage and retrieval or translation into a foreign language) without prior agreement and written consent from the copyright of the owner. Antec reserves the right to make changes to the design and specifications of the instrument and this manual without prior notice.

DECADE Elite, DECADE Lite, ROXY, ALEXYS, ROXY Exceed, INTRO, FlexCell, ReactorCell, μ -PrepCell, ISAAC, HyREF, SenCell and SynthesisCell, SweetSep are trademarks of Antec Scientific. Whatman™ (word and device) and Whatman™ (word only) are trademarks of Whatman international Ltd. SOLVENT IFD™ and AQUEOUS IFD™ are trademarks of Arbor Technologies, Inc. Clarity®, DataApex® are trademarks of DataApex Ltd. Microsoft® and Windows™ are trademarks of Microsoft Corporation. Excel is a registered trademark of the Microsoft Corporation. Chromeleon™ is a trademark of ThermoFisher Scientific. All other trademarks are the property of their respective owners.

The software and the information provided herein is believed to be reliable. Antec shall not be liable for errors contained herein or for incidental or consequential damages in connection with the furnishing, performance, or use of software or this manual. All use of the software shall be entirely at the user's own risk.

CE Declaration of conformity

We Antec Scientific, Alphen a/d Rijn, The Netherlands, declare that the product:

ET 210 Inert Eluent tray

type 192

to which this declaration relates, is in conformity with the following CE directives:

2015/863/EU Directive on Restriction of the use of certain Hazardous Substances (RoHS)

2012/19/EU Directive on Waste Electrical and Electronic Equipment (WEEE)



Only use the manufacturer-supplied plastic PPCO bottle assemblies (pn 184.0205) in combination with the ET 210 eluent tray. These bottle assemblies are specifically intended for the purpose of inert gas (Helium or Nitrogen) pressurization of the head space above the mobile phase. Before use always check if the bottles are undamaged. Never apply gas pressure on damaged/scratched bottles. Manufacturer will not accept any liability for damage, direct or indirect, caused by connecting third-party bottles which do not meet the specifications.

Date: September 21th, 2020
Dr. N.J. Reinhoud (managing Director)

Table of contents

Symbols	5
Intended use	7
Safety instructions	9
CHAPTER 1 - Introduction.....	13
CHAPTER 2 - Installation.....	19
Storage requirements	19
Site Preparation Requirements	19
Unpacking.....	23
Inert gas connection	25
CHAPTER 3 - Operating instructions.....	27
Precautions.....	27
Mobile phase bottles.....	28
Inert gas outlets	29
Manometer.....	30
Gas flow regulator.....	31
CHAPTER 4 - Mobile phase preparation.....	33
Requirements & precautions	33
Preparation	34
CHAPTER 5 - Maintenance & shutdown.....	37
Maintenance	37
Shutting down the Instrument.....	38
CHAPTER 6 - Specifications.....	39
CHAPTER 7 - Troubleshooting.....	41
CHAPTER 8 - Accessories & spare parts	43

Symbols

The following symbols might be used in this guide or may be found on the instrument:



This sign warns about the risk of electric shock. It calls attention to a procedure or practice which, if not adhered to, could result in loss of life by electrocution. Do not proceed beyond a danger sign until the indicated conditions are fully understood and met.



The warning sign denotes a hazard. It calls attention to a procedure or practice which, if not adhered to, could result in severe injury, loss of life or damage or destruction of parts or all of the equipment. Do not proceed beyond a warning sign until the indicated conditions are fully understood and met.



The caution sign denotes a hazard. It calls attention to a procedure or practice which, if not adhered to, could result in damage or destruction of parts or all of the equipment and/or erratic results. Do not proceed beyond a cautions sign until the indicated conditions are fully understood and met.



The biohazard sign draws attention to the fact that use of biological materials, viral samples may carry a significant health risk.



The toxic hazard sign draws attention to the fact that use of toxic solvents or samples may carry a significant health risk.



The hot surface sign calls attention to parts in the instrument that must not be touched, as they may cause burns.



This symbol indicates electrostatic discharge (ESD hazard), damages to system, device, or components can occur if not properly grounded.



This symbol indicates that the waste of electrical and electronic equipment must not be disposed as unsorted municipal waste and must be collected separately. Please contact the manufacturer or authorized representative of the manufacturer for information concerning the decommissioning of equipment.



A device or system marked with CE fulfills the product specific requirements described in the European directives. This is confirmed in a Declaration of Conformity.



This symbol indicates to read the user manual and all safety instructions before using the instrument.



Frame or chassis ground terminal, which can be used as to make additional external grounding connection.



The note sign signals additional information. It provides advice or a suggestion that may support you in using the equipment.



The attention sign signals relevant information. Read this information.

Intended use

The ET 210 Inert eluent tray is used in combination with a (Ultra) High Performance Liquid Chromatography system for the storage and use of LC mobile phases under an inert gas (Nitrogen or Helium) atmosphere applied to the head space of the mobile phase bottles. Antec Scientific advises the use of Helium because of its superior degassing performance.



For research purposes only. While clinical applications may be shown, this instrument is not tested by the manufacturer to comply with the In Vitro Diagnostics Directive.

Operation of the ET 210 eluent tray may involve the use of hazardous materials including corrosive fluids and flammable liquids under head-space pressure. The instrument should only be operated by users with the following expertise:

- Completed degree as chemical laboratory technician or comparable vocational training
- Fundamental knowledge of liquid chromatography and equipment
- Participation in an installation of the system performed by the manufacturer or a company authorized by the manufacturer and suitable training on the system and chromatography software.
- Knowledge and experience in the safe handling of toxic and corrosive chemicals and knowledge of the application of fire prevention measures prescribed for laboratories.



Information on safety practices is provided with your instrument and operation manuals. Before using your instrument or accessories, you must thoroughly read and understand these safety practices. This manual is written for laboratory technicians/scientists skilled in the art, who use the ET 210 eluent tray for (U)HPLC analysis. This instrument may not be serviced by the end-user, only by service engineers authorized by the manufacturer.



Unskilled, improper, or careless use of this instrument can create hazards which can cause death, serious injury to personnel, or severe damage to equipment and property. Observe all relevant safety practices at all times. Only use the device for applications that fall within the scope of the specified intended use. Else the protective and safety equipment of the device could fail.

WEEE

All equipment of Antec Scientific which are subjected to the WEEE directive shipped after August 13, 2005 are compliant with the WEEE marking requirements. Such products are labelled with the “crossed out wheelie”, depicted on the left site.



The symbol on the product indicates that the product **must not** be disposed as unsorted municipality waste.

Collection & recycling information

Please ship the instrument back to the manufacturer (Antec Scientific, the Netherlands) at the end-of-life time of the product. The manufacturer will take care of the proper disposal and recycling of the instrument at its facilities.

Shipping address for the end-of-life products:

Antec Scientific
Hoorn 131
2404 HH Alphen a/d Rijn
The Netherlands

In case of questions, or if further information is required about the collection & recycling procedure, please contact your local distributor.

ROHS



The ROXY Exceed is ROHS compliant and in conformity with Directive EU 2015/863 Restricted use of Hazardous Substances in electrical and electronic Equipment (ROHS).

ISO



Antec Scientific is an ISO 9001:2015 certified company.

Safety instructions

Adhere to the following standard quality control procedures and the following equipment guidelines when using ET 210 eluent tray. The following safety practices are intended to ensure safe operation of the instrument.

Working environment & safety



The intended use of the instrument is the storage and use of LC mobile phases under an inert gas (Nitrogen, Helium) atmosphere applied to the head space of the mobile phase bottles. The instrument is used in combination with a (U) HPLC system in a GLP-approved environment. Operators using the system should have the appropriate education and an extensive understanding of GLP rules and be skilled in the art. Use this system **ONLY** for the intended use. Use of the system for any other purpose might cause unsafe situations.

System Operation



To assure optimal performance we recommend that the instrument is checked regularly and maintenance procedures are carried out. Preventive maintenance contracts are available for that purpose. Please contact your local dealer or the nearest sales office for more information. End-user should not open the instrument, **this may only be done by authorized service engineers.**

Pressure safety



For safe operation make sure that the gas pressure of the inert gas supply line at the laboratory does not exceed the maximum pressure of 5 bar / 73 psi as indicated on the label on the rear panel of the instrument.

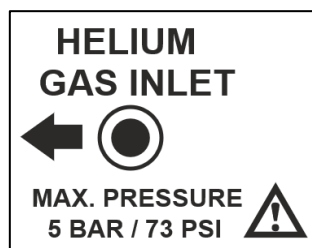

If the output pressure of the inert gas supply is too high use a suitable pressure regulator to down regulate the pressure to the appropriate level (between 1 – 5 bar). Operating above the rated maximum pressure might lead to damage to the instrument or injury.



Only use the manufacturer-supplied plastic PPCO bottles (pn 184.0205) in combination with the ET 210 eluent tray. These bottle assemblies are specifically intended for the purpose of inert gas pressurization of the head space above the mobile phase. Before use always check if the bottles are undamaged. Never apply gas pressure on damaged/scratched bottles. The bottles may never be operated at pressures higher than 1 bar / 15 psi. Higher pressures might cause the bottle to explode.

A pressure relieve valve with a cracking pressure of 1.0 bar/ 15 psi is integrated in the ET210 gas outlet lines as pressure safety, preventing too high operating pressures on the plastic bottles in the case of a malfunction of the internal pressure regulator in the ET210. At pressures above 15 psi the valve will vent the excess of inert gas in the atmosphere. The valve will close again when the pressure drops below 15 psi.

Solvents



The solvents used may be flammable, toxic or corrosive. The room in which the system is installed should be well ventilated to prevent that solvent vapors cause poisoning or ignite and cause a fire. Use of open fire in the vicinity of this system must be strictly prohibited. Do not install the system in the same room with any other equipment that emits or could potentially emit sparks. Provide protective equipment near the instrument, when solvent gets into the eyes or on the skin, it must be flushed away immediately. Provide equipment, such eye wash stations and safety showers, as close to system as possible. Use proper eye and skin protection when working with solvents. Additional safety requirements or protection may be necessary depending on the chemicals used in combination with this equipment. Make sure that you understand the hazards associated with the chemicals used and take appropriate measures with regards to safety and protection. Sample containers (vials) should be sealed to minimize any risks related to solvent vapor.

Biological Hazard



When you analyze biological fluids you need possible precautions and treat all specimens as potentially infectious. Always wear protective And gloves when handling toxic or biologically infectious samples to prevent bio hazards or hazards while working with the DECADE Elite .**If necessary the instrument must be decontaminated before decommis-**

sioning or shipment of the instrument for repair to Antec or its representatives. When shipped to Antec every instrument must be accompanied with a decontamination form which should be completely filled in and signed by the customer. Without this decontamination form the instrument will not be processed by Antec (either repaired or disposed).

Waste disposal



Perform periodic leak checks on LC tubing and connections. Do not close or block the drain in the oven compartment. Do not allow flammable and/or toxic solvents to accumulate. Follow a regulated, approved waste Disposal program. Never dispose of flammable and/ toxic solvents through the municipal sewage system.



Using the ET 210 eluent tray in other ways than indicated in the manual may result in erratic or unsafe operation.

CHAPTER 1

Introduction

Congratulations on your purchase of the ET 210 *Inert* eluent tray. The ET 210 eluent tray enables you to blanket all your LC mobile phases with an inert gas atmosphere (Nitrogen, Helium) in an user-friendly and easy way. An environment of inert gas will prevent diffusion of air into the mobile phase and will keep it free of CO₂ and O₂. Especially in carbohydrate analysis using Anion Exchange Chromatography (HPAEC) based on separation with strong alkaline eluents, dissolved CO₂ can be problematic. Under these circumstances (pH > 12), CO₃²⁻ ions can be easily formed in the mobile phase. These CO₃²⁻ ions bind strongly to the anion exchange groups on the stationary phase and interferes with carbohydrate retention, causing shortened retention times, decrease in column selectivity and loss in resolution. Therefore, keeping the mobile phase free of carbonate is one of the key factors towards reproducible carbohydrate analyses via Anion-Exchange Chromatography. The ET 210 is the perfect choice to keep your mobile phase 'carbonate-free'!



Fig. 1. The ET 210 Inert eluent tray with two mobile phase bottles connected (binary gradient system). The mobile phase bottle assemblies (pn 180.0205) are not part of the ET 210 and sold separately.

Four channels: The ET 210 has four inert gas outlets on the top-front side of the tray, facilitating up to 4 mobile phase bottles which can be independently kept under inert gas atmosphere. Enabling isocratic up to quaternary gradient elution with carbonate-free mobile phases.

Not enough? The ET 210 tray has space for up to 6 mobile phase bottles (pn 180.0250). By using the optional 'Y' shaped dual channel gas line (pn 250.1694) the capacity can be increased to 6 bottles under inert atmosphere.

Easy connect: The gas outlets and gas lines are equipped with valved quick-disconnect fittings. These easy and hassle-free fittings allow you to quickly connect and disconnect your gas lines. Simply press the stainless steel thumb latch to disconnect the fittings and the gas flow is immediately stopped in both directions by means of the integrated spring-loaded valves. An audible click lets you know the coupling is secure when connecting.

Simple operation: A factory preset pressure regulator integrated into the ET 210, will keep the inert gas at the outlets always at the right pressure. So no gas pressure adjustments need to be performed by the user making the instrument simple to operate.

Blanketing & sparging: Besides inert gas blanketing during LC separation the ET 210 can also be used in inert gas sparging mode during the preparation of mobile phases. For that purpose the ET 210 is equipped with a flow control valve for precise adjustment of the gas flow rate, enabling controlled sparging. A dedicated ET 210 gas sparging line (pn 250.1696) is supplied for easy sparging of the mobile phase bottles. Just click the gas sparging line on the mobile phase line of the bottle using the quick-disconnect fittings, open the two-way stop cock on the bottle (venting) and start sparging.



This manual covers the installation, set-up and operation of the ET 210 eluent tray only. Detailed operation instructions for other peripheral LC equipment and parts such as flow cells, pumps, auto samplers, valves, column heaters etc. are described in the manuals shipped with this instrumentation.

Instrument description

ET 210 – Front side



#	Description	#	Description
1	Solvent tray	7	Manometer (0 – 15 psi)
2	Instrument housing		
3	Inert gas outlets (4x)		
4	Flow regulator valve		
5	Tubing guides		
6	Front cover		

ET 210 – Front side (cover removed)



#	Description	#	Description
1	Leakage drain		
2	Tubing guides		
3	Gas line to manometer		
4	Removable front cover*		

The front cover can be partly removed from the housing to feed tubing through the tubing guides. Note that the front cover is still connected via the gas line to the manometer. Do not disconnect the manometer from the gas line.

ET 210 – Rear side



#	Description	#	Description
1	Inert gas inlet		
2	Leakage drain		
3	Warning label with P rating		

CHAPTER 2

Installation

Storage requirements

The ET 210 eluent tray is shipped in a shipping box to your facility with the following dimensions:

Equipment	Dimensions storage box*
ET 210 eluent tray	67 (D) x 52 (W) x 33 (H) cm (26.4 x 20.5 x 13.0 in)

*) When the ET 210 eluent tray is shipped as a part of the ALEXYS LC-EC system it will be packed together with a P 6.1L pump in a shipping box

The total weight of the instrument with packaging material is 6,3 kg (13.9 lbs). Make sure to have sufficient space to store the packed instrument under the following storage conditions:

Parameter	Requirement
Storage temperature	-25 to +50 °C (-13 to +122°F)
Storage humidity	Max humidity 85%, non-condensing

Site Preparation Requirements



It is evident that (for as far it is not specified in this document) the installation site must comply with all applicable local laws and regulations with mechanical installations, building safety, and use of potentially hazardous materials/chemical and disposal thereof, etc.

For a successful onsite installation of the instrument, please arrange the following requirements at your location in advance:

Laboratory requirements

Table I. Environmental specifications

Parameter	Requirement
Operating temperature	10 - 35 °C (50 – 95°F)
Operating humidity	20 – 80%, non-condensing



Do not place the instrument next to heating or cooling pipes or expose the instrument to direct sun light or expose it to air drafts (AC system / open windows).

Requirements for the laboratory bench on which the instrument will be installed:

- Stable, clean, flat and vibration-free surface.
- Enough mechanical strength to hold at least the weight of an complete (U) HPLC system including ET 210 eluent tray.
- An ET 210 eluent tray without bottles weights 3.8 kg (8.4 lbs.). A full-dressed ET 210 eluent tray with 6 filled mobile phase bottles may weigh up to 15 kg or more.
- An ET 210 eluent tray itself has the following dimensions 54 (D) x 37 (W) x 11 (H) cm = 21.3” (D) x 14.6” (W) x 4.3” (H). Take into account 15 cm of clearage on the back side, that additional space is required to connect the inert gas supply line. The ET 210 with 2 L mobile phase bottles placed in the tray will be 45 cm (17.7 lbs.) high.

Inert gas

Arrange a Nitrogen or Helium source of sufficient purity (Helium 5.0 or Nitrogen 99.999%). The gas source should be regulated to 1 – 5 bar (15 – 73 psi). The ET 210 is delivered with a 3 meter polyurethane (PU, shore 95A) gas inlet line which needs to be connected to the gas source. Therefore, make sure that the gas source is located within 3 meters from the ET

210. The tubing has an ID of 3/32" (2.4 mm) and outer diameter of 5/32" (4 mm). The tubing can be connected using 4 mm push-in connectors.



Make sure to have a suitable connector/converter available to be able to make the connection to your specific regulator or inert gas supply line in the laboratory.



Operating above the rated maximum input pressure might lead to erratic operation or degradation of performance of the device. The max pressure of the inert gas inlet line is rated 14.5 bar (210 psi) at 25°C (77°F). Above that pressure the tubing may rupture which may lead to damage or injury.

At higher ambient temperatures the max pressure rating of the PU tubing will be significantly degraded. For example at 65°C (149°F) Pmax is declined to 5.9 bar (85 psi). Therefore, do not use the device in ambient conditions exceeding 35°C (95°F).

Chemicals



Mobile phase and flush/storage solutions must be clean as it is in direct contact with the working electrode of the electrochemical reactor cell. High purity chemicals including water is a prerequisite. So all chemicals should be electrochemically clean, HPLC grade or better. For water used for the preparation of mobile phases a water purification apparatus is advised which is able to supply high purity deionized water with resistivity of >18 MOhm.cm and low TOC level (<10 ppb). For reference, in the table on the next page the chemicals used in the laboratory of Antec Scientific are listed for method development in Carbohydrate analysis.

Table 2. Brands and purities of chemicals used for application development at Antec Scientific.

Component	Purity	Brand	Order no	Mw	kg/L
Sodium hydroxide*					
Sodium hydroxide (NaOH), approx. 50% in water	Pro analyse, carbonate free	Boom	80011912	40.00	D:1.57
Sodium Hydroxide Solution (50% w/w/Certified)	Certified grade	Fisher Scientific	SS254500	40.00	D:1.56
Sodium hydroxide solution, 50-52%	Eluent for IC	Sigma Aldrich	72064	40.00	D:1.53
Potassium hydroxide*					
Potassium hydroxide (KOH), 45% w/v in water (13.5 M)	HPLC grade, carbonate free	Fisher Scientific	15670680	56.105	D:1.45
Sodium Acetate					
Sodium acetate trihydrate (CH ₃ COONa.3H ₂ O)	HPLC grade for EC detection	Fisher Scientific	S/2052/50	136.08	
Sodium acetate trihydrate (CH ₃ COONa.3H ₂ O)	>=99%, BP, Ph.Eur grade	Fisher Scientific	S/2000/60	136.08	
Sodium acetate trihydrate (CH ₃ COONa.3H ₂ O)	HPLC grade	Baker	0393	136.08	
Acetonitrile	HPLC grade	Acros	268270025	41.05	0.79
Water	TOC <10 ppb and deionized, resistivity >18 MOhm-cm (Barnstead Easy pure II)				

* The contents of Hydroxide in commercial hydroxide solutions specified on the bottles are always by approximation. Always use the actual contents of hydroxide as stated in the certificate of analysis to calculate the amount of solution needed to make mobile phases. The certificate of analysis may be delivered with the bottle or can be requested/downloaded from the manufacturer (web site).

Unpacking

Inspect the *transport box* for possible damage as it arrives. Immediately inform the transport company in case of damage, otherwise she may not accept any responsibility. Keep the transport box as it is designed for optimum protection during transport and it may be needed again. Carefully unpack the system and inspect it for completeness and for possible damage. Contact your supplier in case of damage or if not all marked items on the checklist are included. Prior to shipment, your detector has been thoroughly inspected and tested to meet the highest possible demands. The results of all tests are included.

See check list below for reference:

- | | | |
|-----|--|-----------------------|
| (1) | Delivery is in accordance with order | <input type="radio"/> |
| (2) | Delivery is undamaged | <input type="radio"/> |
| (3) | All items on checklist(s) are included | <input type="radio"/> |
| (4) | Certificates of performance | <input type="radio"/> |
| (5) | User manual is included on USB stick | <input type="radio"/> |

*) Note that the

To unpack the ET210 Eluent tray, lift it from its box by both hands (Fig. 2). **Never lift the tray at its front panel**, but at its sides.

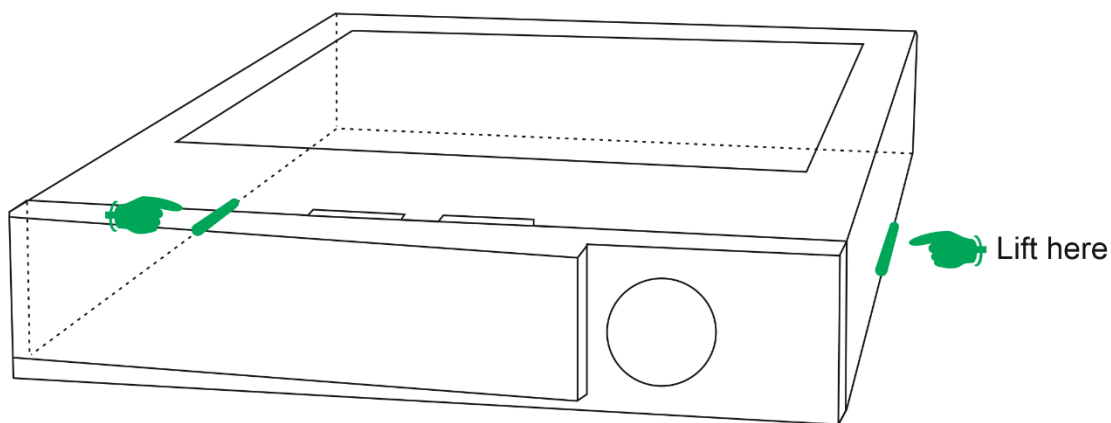

Fig. 2. Lift instructions ET 210 Eluent tray.

Place the ET210 on top of the stack of ALEXYS HPLC instruments. Take care that the instrument feet are resting in the notches of the top panel of the instrument below it (either a P6.1L pump or AS6.1L autosampler).



Fig. 3. ALEXYS HPLC system stack with ET 210 on top.

Make sure to connect the leak management system of the ALEXYS (U) HPLC system, consisting of a funnel together with drain tubing (black arrow in picture above). These parts are delivered with the P6.1L pump and AS6.1L autosampler. Please refer to the user manuals of these instruments for detailed installation instructions. The funnel of the instrument below the ET 210 is positioned under the drain outlet from the eluent tray. In the event of a leakage of one of the bottles in the eluent tray, all liquid will be channeled into a waste container.

The mobile phase and wash bottle lines can be fixed through the tubing guide of the ET 210. To do so gently remove the front panel and guide the tubing through as indicated by the green arrow in the picture above. Note that the front cover is still connected via the gas line to the manometer. Do not disconnect the manometer from the gas line.

Gas inlet connection

Connect the PU tubing (pn 250.1692 ET 210 gas inlet tubing, 3m) supplying the inert gas to the ET 210. The inert gas inlet connector is located at the rear panel on the right side. To connect the tubing press the outer ring of the push-in connector with your fingers and simultaneously push the tubing as deep as possible in the opening in the center of the connector. See figure on the next page. To remove the tubing, press the ring and pull the tubing to release.



Before removing the PU tubing on the gas inlet of the ET 210, always check if the tubing is connected to a gas source and the inert gas source is closed.

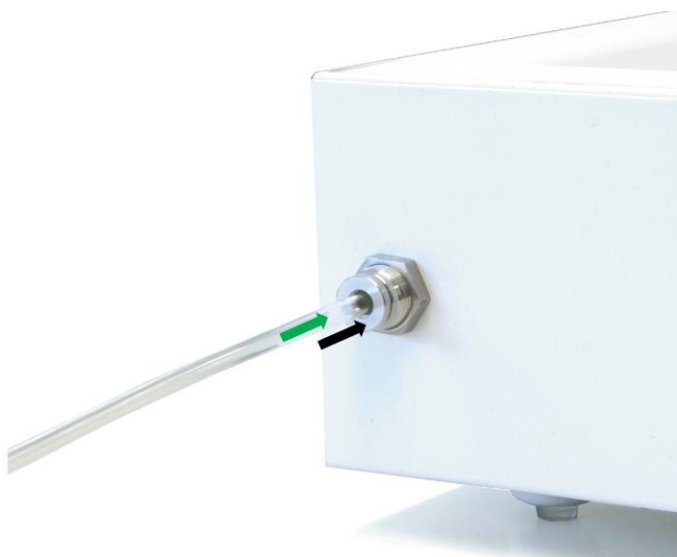

Fig. 4. To fix the gas inlet line. Depress ring (black arrow), insert tubing as far as possible (green arrow) and subsequently release the ring. The tubing will be secured with a gas tight connection.

Make sure the source gas pressure is regulated to 1 – 5 bar (15 – 73 psi) and open the gas source. The ET 210 will now be pressurized and ready for use.



Operating above the rated maximum input pressure might lead to erratic operation or degradation of performance of the device. The max pressure of the gas inlet line is rated 14.5 bar (210 psi) at 25°C (77°F). Above that pressure the tubing may rupture which may lead to damage or injury.

CHAPTER 3

Operating instruction

Precautions

Before operating this device with mobile phase bottles. Pay attention to the following points.

When working with HPLC solutions and mobile phases take the following precautions:



Use proper eye and skin protection when working with solvents. The solvents used may be flammable, toxic or corrosive. Organic solvents are toxic above a certain concentration. Ensure that work areas are always well-ventilated! Use of open fire in the vicinity of this system must be strictly prohibited. Do not install the system in the same room with any other equipment that emits or could potentially emit sparks. Wear protective gloves, safety glasses and other relevant protective clothing when working on the device!

Use the instrument only in combination with manufacturer supplied plastic polypropylene copolymer (PCCO) bottles.



Only use the manufacturer-supplied plastic PPCO bottles (pn 184.0205) in combination with the ET 210 eluent tray. These bottle assemblies are specifically intended for the purpose of inert gas (Nitrogen or Helium) pressurization of the head space above the mobile phase. Before use always check if the bottles are undamaged. Never apply gas pressure on damaged or scratched bottles. The bottles may never be operated at pressures higher than 1.0 bar / 15 psi. Higher pressures might cause the bottle to explode.

Inert gasses, especially Helium, are expensive. To reduce the risk of losing Helium in the atmosphere by leakage:

- Make sure that all connections of gas lines, bottle & cap, fittings on the cap are closed gas-tight before use of the system.
- Use a low gas flow rate setting for gas blanketing.
- There are convenient portable gas leak detector available (for example the GL sciences LD239 Gas Leak Detector) to check for leaks.



Mobile phase bottles

The manufacturer-supplied plastic PPCO bottle assembly (pn 184.0205) consist of parts listed below. Before using the bottles with the device please identify the parts and understand their function.



Fig. 5. PPCO bottle assembly (pn 184.0205).

#	Description	#	Description
1	PPCO bottle	7	Quick connector mobile phase line
2	B53 cap with 3x 1/4-28 ports	8	Inert gas supply line
3	2-way stopcock	9	Quick connector inert gas line
4	1/4-28 PP plug		
5	Mobile phase line		
6	1/8" OD tubing Luer connector		

Below the functionality is explained of some of the parts:

#	Functionality
2	A cap with B53 thread and a Teflon inlay with 3x 1/4-28 ports for an gas-tight closure of the mobile phase bottle. Two of the ports are used for the inert gas and mobile phase line. The third port is closed using a PP plug (4).
3	The 2-way stopcock can be used to close the inert gas line in case you want to store the mobile phase under inert atmosphere outside of the ET 210 eluent tray. Simple (a) close the stopcock, (b) remove the gas line from the ET 210 by disconnection the quick connector (9) and (c) disconnect the gas line from the stopcock by disconnecting the Luer connector (6).
4	The PP plug is normally closed during operation but can be opened to vent out air or inert gas in the head space of the bottle .
7	Grey 'quick-connect' valved socket (PP) to make a leak-free/no spillage connection to the low-pressure mobile phase inlet line of the pump. At disconnect the valved socket will automatically close and stop the flow of mobile phase
9	White 'quick-connect' valved plug (Acetal) to make a leak-free and gas tight connection to the inert gas line to the mobile phase bottle. At disconnect the valved plug will automatically close and stop the flow of inert gas.

For guidelines for the preparation of eluents for anion-exchange chromatography, see next chapter.

Inert gas outlets

The ET 210 is equipped with 4 inert gas outlet sockets, marked A – D, located at the top panel on the front left side. These white valved sockets are automatically closed when there are no gas lines connected.

To connect a gas line to the ET 210 follow the procedure below. Before connecting make sure that the gas line on the other side is closed (stopcock closed).

1. Engage the plug into the socket (see figure on the next page, green arrow)
2. Press the latch on the socket (black arrow) with your finger to unlock the socket.

3. Push the plug into the socket until you hear an audible click of the metal retaining clip of the socket falling into the groove of the plug.

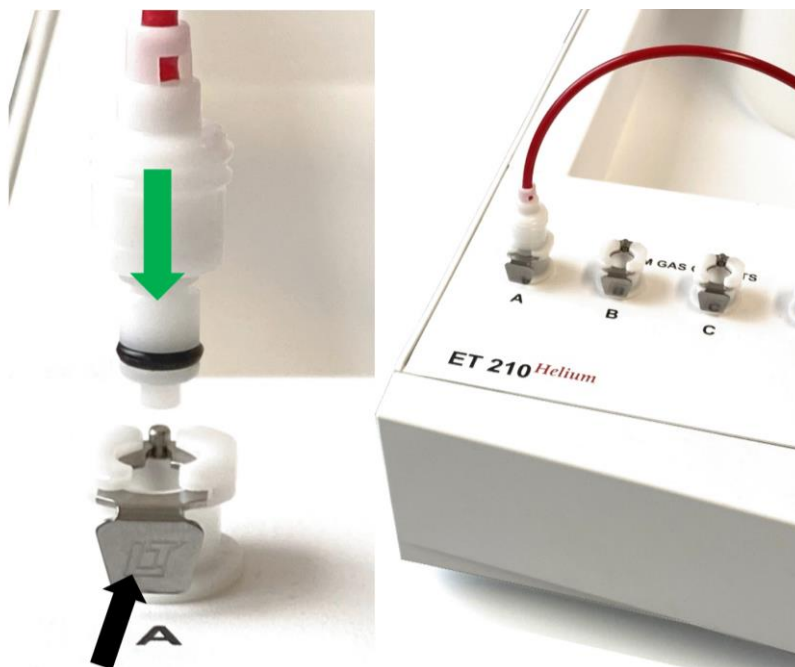

Fig. 6. Connecting a gas line to an ET 210 gas outlet. Left: plug engaging the ET 210 socket. Right: socket with gas line connected.

Manometer

The manometer is located on the front panel of the ET 210 and displays the actual gas pressure of the ET 210 gas outlets in psi and bar.



Fig. 7. ET 210 manometer: scale in PSI (0–15 psi) and bar (0–1 bar).

The maximum gas output pressure of the ET 210 is 0.4 bar / 6 psi. The typical output pressure may range between 0.1 – 0.4 bar (1.5 - 6 psi) inert gas pressure, depending on the gas inlet pressure of the source. It might happen that at start-up, when opening the gas source, the manometer will show some slightly higher pressure than 0.4 bar. This 'overshoot' is due to the instantaneous pressurization of the ET 210 in a closed state, the pressure will quickly stabilize to the typical values when the gas outlets are used.

Gas flow regulator

The valve for the regulation of the gas flow is located on the top panel at the front right side.



Fig. 8. ET 210 manometer: scale in PSI (0 – 15 psi) and bar (0 – 1 bar).

The flow regulator is pre-set at the factory on a low gas flow rate suitable for inert gas blanketing. The flow rate can be adjusted by means of the blue adjustment knob: turning the knob counter-clockwise will increase the flow rate, turning it clockwise will decrease the gas flow rate. The flow regulator has a locking nut (indicated with the black arrow). The locking nut can be used to set/fix the flow rate for inert gas blanketing. This is convenient when alternating between gas purging during mobile phase preparation and Heli blanketing during LC analysis. During inert gas purging a higher flow rate is used compared to blanketing. After mobile phase preparation the gas flow rate can be easily adjusted back to the preset for blanketing.

CHAPTER 4

Mobile phase preparation

In this chapter the procedure is described for the preparation of carbonate-free mobile phase for anion-exchange chromatography. This is the procedure we at Antec Scientific advise and use in our laboratory. As an example, the preparation of a CO₂-free sodium hydroxide mobile phase, with an arbitrary concentration of NaOH is described in the next paragraphs.



Prepare and blanket all mobile phases in such manner, even the bottle of DI water used as mobile phase in LPG gradient analysis of carbohydrates. This is one of the keys towards reproducible and sensitive carbohydrate analysis

Requirements & precautions

For the preparation of the mobile phase the following parts are needed:

- ET 210 eluent tray (pn 192.0050), installed and ready
- 2 Liter PPCO bottle assembly (pn 184.0250)
- Chemicals and solvents (DI water, carbonate-free 50 w% NaOH solution), see table 1 in chapter 2
- Magnetic stirring device and stirrer bar
- Gas sparging line (pn 250.1696) from the ET 210 accessory kit
- Protective gear (safety glasses, lab coat, nitril gloves etc.)
- General laboratory tools for the handling of chemicals and solvents like pipettes with plastic tips, flasks, graduated cylinders etc. Make sure these tools are clean.



Use proper eye and skin protection when working with solvents and chemicals. The solvents used may be flammable, toxic or corrosive. Ensure that work areas are always well-ventilated! Wear protective gloves, safety glasses and other relevant protective clothing when preparing mobile phases.

Do not use glass wear to handle sodium hydroxide solutions. The mobile phase should be stored in suitable plastic containers (HDPE, PP, PPCO) instead of glass. NaOH is a strong etching agent and will react with the inner glass wall resulting in the release of silicates and borates which can have a detrimental effect on the anion-exchange separations. It is well known that the presence of borate in eluents can cause a significant loss of peak efficiency (tailing), especially for mannose, fructose, and reduced monosaccharides.



Only prepare a NaOH mobile phase using a 50% w/w carbonate-free NaOH stock solution (commercially available). Commercially available NaOH pellets are not acceptable for eluent preparation, because they are always covered with a thin adsorbed layer of sodium carbonate. Furthermore, commercial 1 mol/L NaOH solutions (and other less concentrated NaOH solutions) are also not advised for the preparation of mobile phases. Such solutions contain high concentrations of carbonate ions.

Take care when handling the 50% NaOH stock solution to avoid trapping of carbonate. Do not shake the bottle. Pipette from the middle of the NaOH solution if possible (depending on your pipette length). Any carbon dioxide present in the solution will precipitate as sodium carbonate to the bottom of the flask, leaving the top part of the solution virtually carbonate free. Do not use the last quarter of the bottle content, because it might contain carbonate. Always use clean and if possible sterile plastic (serological) pipettes or pipette tips.

Preparation

For the preparation of the mobile phase execute the steps below:

1. Take a clean and empty 2 Liter PPCO bottle assembly. In the case the bottle is new, it is advised to sanitize/rinse the bottle first with a 2 mol/L NaOH solution followed by flushing with DI water.
2. Remove the red gas outlet gas line, but leave the 2-way stop cock on the bottle.
3. Fill the bottle with the total amount of DI water required to make the NaOH solution.
4. Add a clean magnetic stirrer bar and cap the bottle with the stop cock open.
5. Degas the bottle with DI water for 15 minutes in an ultrasonic bath.

6. Transfer the bottle onto a magnetic stirring device next to the ET 210 eluent tray. See figure below.



Fig. 9. Set-up for mobile phase preparation using inert gas sparging.

7. Connect the gas sparging line (pn 250.1696): connect the white plug to one of the outlet sockets of the ET 210, and connect the grey plug to grey socket of the mobile phase line.
8. Open the 2-way stopcock.
9. Adjust the flow regulator valve to a level (turn counter clockwise) that a reasonable flow of inert gas bubbles is sparging through the DI water.
10. Switch on the magnetic stirrer to gently stir the solution without the formation of a vortex. Avoid vigorous stirring because it might introduce air.
11. Sparge the solution under gentle stirring for 15 minutes to saturate the water with inert gas and to remove the residual air in the solution.
12. Stop the stirring but keep the sparging on during the next steps.

13. Gently loosen the bottle cap but don't remove it completely (let the cap resting on the bottle opening).
14. Pipette the appropriate amount of 50% NaOH solution following the procedure described in the precautions.
15. Lift the cap a bit and dispense the amount of 50% NaOH solution from the pipette into the water with the pipette tip immersed in water.
16. Close the bottle cap and start stirring again.
17. Let the solution stir for another 10 -15 minutes.



When using Nitrogen for sparging pls shortly sonicate (5 minutes) again to remove excess of N2 gas bubbles from the solution formed during sparging.

18. Close the 2-way stopcock.
19. Reduce the gas flow rate for gas blanketing by turning the blue adjustment knob clock wise until it is blocked by the blocking nut.
20. Remove the gas sparging line (pn 250.1696). First remove the white plug from the ET 210 outlet socket and subsequently remove the grey plug from the mobile phase line.
21. Transfer the bottle into the ET 210 Eluent tray.
22. Connect the open gas output gas line into the ET 210 outlet socket to purge out the remaining air.
23. Subsequently connect the open end to the stopcock on the bottle.
24. Open the stopcock to pressurize the head space.
25. Insert the plug of the mobile phase line (connected to the P6.1L pump degasser inlet) to the receiving socket of the mobile phase line of the bottle.
26. Purge and prime the mobile phase tubing and pump head with carbonate-free mobile phase.

You are now ready to start your analysis.

CHAPTER 5

Maintenance & Shutdown

Maintenance

In this paragraph all maintenance is described which can be performed by the end-user, all other maintenance & service procedures may only be performed by authorized service engineers only.

Periodic check for leakage

Perform leak checks on LC tubing, gas tubing and its connections on a daily basis and check if the drain on the bottom of the eluent tray is not blocked or closed. Do not allow flammable and/or toxic solvents to accumulate. Follow a regulated, approved waste disposal program. Empty and clean waste container regularly. Never dispose of such products through the municipal sewage system. Check daily that the mobile phase bottles contain enough mobile phase for the number of analysis planned to be executed. Check the mobile phase bottles regularly for damage or other irregularities. **Replace damaged or scratched bottles and caps immediately, never pressurize them.**



Cleaning

In general, the ET 210 eluent tray does not need much maintenance. The outside of the ET 210 may be cleaned with a non-aggressive cleaning liquid.



Do not use any organic solvents to clean the exterior of the eluent tray, because this may lead to damage of the paint layer.

In case of leakage in the eluent tray (tubing, connectors, bottles etc.) remove the spilled mobile phase or other solutions as soon as possible because this may damage the paint layer, or result in the deposition of salt crusts (in case of buffered mobile phases), which could block the drain in the bottom of the cell eluent tray. Remove any dust/dirt from the gas outlet sockets and gas flow regulator valve.

Periodic check gas tightness of ET210

Regularly check the leak tightness of the ET210, or in case a leak is suspected (abnormal gas consumption). To check the leak tightness perform the following steps:

- Disconnect all red gas lines (pn 250.1694 or 250.1695) from the ET210 gas outlets (A-D).
- Write down the pressure reading on the manometer on the front side of the instrument (figure 7).
- Keep the inlet gas line (pn 250.1692) on the backside of the device connected to the gas inlet (see fig 4), and close the valve of the laboratory gas supply to stop the flow of gas.
- Wait for 15 minutes and compare the pressure reading on the manometer with the one written down.
- In case the pressure reading is stable the device is OK.

In case of a loss in pressure go to chapter 7 (the troubleshooting section) to get directions to solve the problem.

Shutting down the Instrument

There are a couple of steps to take to prepare the eluent tray for storage when not in use for a longer period of time. Perform the following procedure:

- Disconnect all gas outlet gas lines from the ET 210
- Disconnect all mobile phase lines from the bottles.
- Clean (with DI water), dry and store the mobile phase bottles for future use.
- Close the inert gas source in the laboratory.
- Remove the inlet tubing from the rear panel of the instrument
- To depressurize the ET 210, just connect an open gas outlet line to one of the outlet sockets. Remove it again when done.
- Clean and dry the ET 210 eluent tray.

The ET 210 is now ready for storage.

CHAPTER 6

Specifications ET 210 eluent tray**General**

Operating temperature	10 - 35°C (50 – 95°F), indoor use only
Operating humidity	20 - 80% RH, non-condensing
Storage temperature	-25 - +50°C (-13 to +122°F),
Storage humidity	Max. RH 85%, non-condensing
Dimensions	54 (D) x 37 (W) x 11 cm (H) = 21.3" (D) x 14.6" (W) x 4.3" (H)
Weight	3.8 kg (8.4 lbs.)
Format	Stackable on P6.1L or AS 6.1L
Capacity	4x 2L PPCO eluent bottle
Intended use	Eluent pressurization & sparging system
Suitable gas source	Nitrogen 5.0 or Helium 5.0 (purity > 99.999%)

Pneumatics

<i>Inlet</i>	
Connector	4 mm push-in connector
Inlet tubing	3/32" ID x 5/32" OD Polyurethane 95A shore
Operating pressure range	1 - 5 bar (15 - 73 psi)
Max. pressure	5 bar/73 psi (from laboratory inert gas source)
<i>Outlet</i>	
Connectors (4 channels)	4x valved 'quick connect' socket for 1/8" tubing
Outlet tubing	1/16" ID x 1/8" OD Polyurethane 85A shore (to mobile phase bottles)
Operating pressure range	0.2 - 0.4 bar (3 - 6 psi), depending on inlet pressure
Max. pressure	0.4 bar/6 psi
Flow rate	Adjustable using manual flow regulator valve
Pressure gauge	0-15 psi, ANSI Grade B Accuracy, Scale: Dual (lb/sq. inch - bar - x 100 kpa)
Safety	Pressure relief valve, cracking pressure 1.0 bar/15 psi

CHAPTER 7

Troubleshooting

Even though great care was taken in the design of the ET 210 eluent tray, problems may occur during operation of the instrument. The information in this chapter may help you to identify the source of the problems and gives advise how to solve it.

In the next sections some errors are described. In the event that the problems cannot be solved after following the instructions in this troubleshooting section, contact your local supplier for advise and repair. In any case do not perform any repair the internal parts of the instrument yourself.

No pressure reading on manometer

Possible cause	Remedy
Inert gas source closed	Check if valve/regulator of the laboratory inert gas supply is open
No inlet tubing connected or tubing damaged/ruptured	Insert tubing or replace tubing
Defect manometer	Call for service to replace manometer
Internal leakage of tubing, connections or parts in the device	Switch of inert gas source immediately and call for service

No gas flow from outlets

Possible cause	Remedy
Flow regulator valve closed	Open flow regulator valve
No gas outlet lines connected	Connect gas lines
Valve of outlet socket closed/blocked	Try to re-connect plug of gas outlet lines again. If this does not work, call for service to replace outlet socket(s) of ET 210
Valve of plug on gas outlet gas line closed/blocked	Try to re-connect plug of outlet gas lines again. If this does not work, replace the valved plug on the gas outlet line
2-way stopcock closed	Open stopcock connected to the gas outlet line

Significant loss of inert gas overnight

Possible cause	Remedy
Internal leakage of tubing, connections or parts in the device	Switch of gas source immediately and call for service
Leakage over the outlet connector	Replace worn-out O-ring on the 'quick connect' plug.
Ruptured/damaged gas outlet lines	Replace the gas outlet line
Leaking bottle and gas line connections	Close cap and connections thoroughly, until a gas-tight closure is establish, in case necessary replace faulty parts.

Pressure relief valve open

Possible cause	Remedy
Defect pressure regulator	Switch of inert gas source immediately and call for service

In the case the instrument has to be shipped back to the manufacturer for repair, it has to be accompanied with (a) an Return to Manufacturer Authorization (RMA) number and (b) decontamination form which should be completely filled in and signed by the customer. Without this decontamination form the instrument will not be processed by Antec (either repaired or disposed).

CHAPTER 8

Eluent tray accessories**ET 210 accessory kit**

The ET 210 eluent tray is shipped together with a number of parts. The listing in Table below may not be complete, see check list of delivery for complete listing.

Table III. Accessory kit (pn 192.0200) ET 210 eluent tray.

Part number	Description
250.1690	Tubing marker set A - D, 1/8" OD tubing
250.1692	ET 210 gas inlet tubing, 3m
250.1696	ET 210 gas sparging line

The following optional accessories / spare parts are available for the ET 210 and bottles.

Table IV. ET 210 optional accessories & parts.

Part number	Description
184.0205	PPCO bottle assembly, 2L, Inert gas
184.0207	PPCO bottle, 2 L, without B53 cap
184.0206	B53 cap with 3x 1/4-28 ports
250.1691	Plug 1/4-28, PP
250.1693	MP tubing assembly for B53 cap
250.1694	ET 210 dual channel gas line
250.1695	ET 210 single channel gas line
250.1697	Adapter, Luer female to 1/4-28 male, PP
250.1698	2-way stopcock, Luer thread, Kynar
250.1699	1/8" tubing connector, Female Luer, PP

For purchase of these parts contact your local supplier.

Note that pn 184.0205 PPCO bottle assembly, 2L, inert gas is the complete bottle assembly for the ET 210 with all the necessary parts, ready for use.



Fig. 10. Pn 184.0205 PPCO bottle assembly, 2L, inert gas.